



Electrolux



EasyLine™ Dry Iron EDI1004/EDI1014

EN Instruction book
Before using the iron for the first time, please read the safety advice carefully.

CNS 说明书
首次使用熨斗之前，请先仔细阅读安全建议。

CNT 說明手冊
第一次使用本熨斗之前，請先仔細閱讀安全建議。

KR 설명서
다리미를 처음 사용하기 전에 안전 지침을 자세히 읽어 보십시오.

ID Buku petunjuk
Sebelum menggunakan setrika ini untuk pertama kalinya, bacalah petunjuk keselamatan secara cermat.

Nomor MKG: IMKG.1519.07.2022

Produk: Setrika Listrik

TH คู่มือแนะนำการใช้งาน
ก่อนใช้งานเตารีดเป็นครั้งแรก กรุณา อ่านคำแนะนำเพื่อความปลอดภัย โดยละเอียด

VN Sách hướng dẫn
Trước khi sử dụng bàn là lần đầu tiên, vui lòng đọc kỹ lời khuyên về sự an toàn.

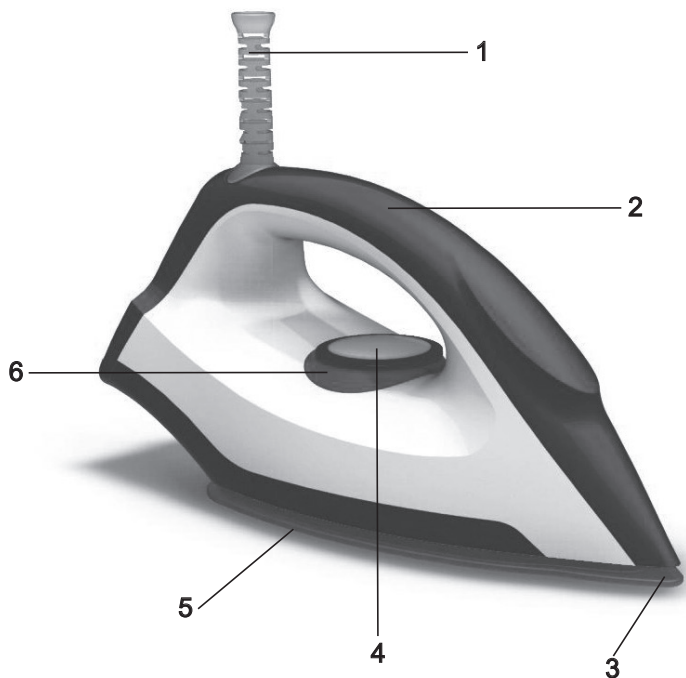

EN

Components

1. Power cord protector
2. Handle
3. Button-guard
4. Temperature selector
5. Soleplate*
6. Power indicator light

CNS

組件圖

1. 电源线保護套
2. 把手
3. 鈕扣保護裝置
4. 溫度旋鈕
5. 底板*
6. 電源指示燈

CNT

組件圖

1. 電源線保護套
2. 把手
3. 鈕扣保護裝置
4. 溫度調控鈕
5. 底板*
6. 指示燈

KR

구성요소

1. 전원 코드 보호대
2. 핸들
3. 버튼 보호대
4. 온도 조절기
5. 다리미 밀판*
6. 전원 표시등

*specifications vary by model / 規格因型號而異 / 詳細規格因型號而有不同 / 세부사양은 모델 별로 다를 수 있습니다

Safety advice / 安全提示

EN

Read the following instruction carefully before using the product for the first time.

- This appliance is not intended for use by persons (including children) with reduced physical, sensory or mental capabilities, or lack of experience and knowledge, unless they have been given supervision or instruction concerning use of the appliance by a person responsible for their safety.
- Children should be supervised to ensure that they do not play with the appliance.
- The appliance may only be connected to a power supply where voltage and frequency comply with the specifications on the rating plate.

- The iron is not to be used if it has been dropped, if there are visible signs of damage on the iron or its cord.
- The appliance must only be connected to an earthed socket.
- If the appliance or the supply cord is damaged, it must be replaced by the manufacturer, its service agent or similar qualified person, in order to avoid hazard.
- The iron must be used and rested on a stable surface. When placing the iron on its stand, ensure that the surface on which the stand is placed is stable.
- Never leave the appliance unattended while connected to the supply mains.

- The appliance must be switched off and the main plug withdrawn each time after use, before cleaning and maintenance.
- The main cable must not come into contact with any hot parts of the appliance.
- Do not immerse the appliance in water or any other liquid.
- This appliance is intended for domestic use only. The manufacturer cannot accept any liability for possible damage caused by improper or incorrect use.

CNS

首次使用本产品前，请仔细阅读以下说明。

- 本产品不宜由身体残疾、知觉或智力水平不佳者（含儿童）或缺乏必要的经验或知识的人士使用，除非其安全监护人给予了他们有关本机使用的指导或说明。
- 应监护儿童，确保其不会玩耍本产品。
- 本产品仅可连接符合本产品铭牌上电压及频率规格电源。

- 如果熨斗曾经跌落，且熨斗或电源线已经明显损坏，请勿再次使用。
- 本产品必须仅连接接地插座。
- 如果本产品或电源线出现损坏，为避免出现危险，必须由制造商、其维修代理或具有类似资质的人士进行更换。
- 一定要在平稳的表面使用和放置熨斗。熨斗立放在其底座上时，必须确保底座所处的表面平稳。
- 在本产品接通电源期间，使用者不得离开。

- 每次使用之后，以及在清洁和维护之前，请关闭本产品，并从插座中拔出电源插头。
- 电源线不得接触到本产品的任何高温部件。
- 请勿将本产品浸入水中或其它液体之中。
- 本产品仅限于家庭使用。对于不当或错误使用可能造成的损失或损坏，制造商一概不予负责。

第一次使用本產品之前，請先詳閱以下說明。

- 本產品不適合給行動、感官或心理方面患有障礙，或是缺乏相關經驗和知識的人士（包括兒童）使用。除非經由他人指導操作並保障安全，否則不建議以上人士使用本產品。
- 請務必避免兒童將本產品拿來玩耍。
- 請務必依照本產品所要求的規格，插上有提供相同電壓和頻率的電源插座。

- 熨斗若有摔壞、出現明顯瑕疵、電線脫落等情形時應停止使用。
- 本產品只能夠插在有經過接地處理的電源插座上。
- 倘若產品本身或電源線有損壞情形，請務必交由製造廠商或由其核准認可之維修商或合格技師處理，以避免發生危險。
- 熨斗必須在平坦且穩固的表面上置放、使用。熨斗以直立方式置放時，應確認表面是否穩固。

- 產品在接通電源期間，千萬不要轉移注意力去處理其他事情。
- 產品於每次使用後或是進行清理維護之前應確實關閉，並且將電源線從插座拔出。
- 不要讓電源線接觸到產品上的任何發熱之處。
- 不要將本產品浸泡在水或是任何液體中。
- 本產品僅供家庭使用。本廠對於不當或是不正確使用所可能造成的損壞均不負責。

CNT

본 제품을 처음으로 사용하기 전에 다음 지침을 주의 깊게 읽으십시오.

- 본 제품은 신체적 능력이나 감각 또는 정신에 장애가 있거나 경험 및 지식이 부족한 사람이 사용하도록 제조되지 않았으며, 이러한 사람들은 안전을 책임질 수 있는 사람이 본 제품의 사용과 관련하여 감독 또는 지도를 실시하는 경우에만 본 제품을 사용해야 합니다.
- 아이들이 본 제품을 가지고 놀지 않도록 하십시오.
- 본 제품은 명판에 기재된 전압 및 주파수 사양과 일치하는 전원 플러그에만 연결해야 합니다.

- 다리미를 떨어뜨려 본체 또는 전원 코드에 손상의 흔적이 보이거나 물이 새는 경우, 사용해서는 안 됩니다.
- 본 제품은 반드시 접지된 소켓에만 연결해야 합니다.
- 본 제품이나 전원 코드가 손상된 경우, 위험을 방지하기 위해 제조업체나 서비스 센터 또는 이에 준하는 자격을 갖춘 직원에 의해 손상된 부분을 교체해야 합니다.
- 다리미는 평탄한 면 위에서 사용하거나 보관해야 합니다. 다리미를 스탠드 위에 두는 경우 스탠드를 평탄한 곳 위에 두어야 합니다.
- 전원에 연결한 채로 본 제품을 방치하지 마십시오.

- 본 제품은 사용한 후나 청소 또는 유지보수/수리작업을 하기 전에는 반드시 스위치를 끄고 전원 플러그를 뽑아야 합니다.
- 전원 케이블이 본 제품의 뜨거운 부분에 닿지 않게 하십시오.
- 본 제품이 물이나 기타 액체에 젖지 않게 하십시오.
- 본 제품은 국내에서만 사용하도록 제조되었습니다. 제조업체는 부적절하거나 잘못된 사용으로 인해 발생할 수 있는 손상에 대해 어떠한 법적 책임도 지지 않습니다.

KR

Getting started / 使用说明 / 使用說明 / 시작하기

EN

- 1. Before first use.** Remove all adhesive remains and gently rub with a dampened cloth. When turned on for the first time, temporary odours may occur.
- 2. Plug power cable into a power outlet.** Power indicator light turns on. Set temperature by turning temperature selector to adequate choice. When the light turns off, iron is ready to be used.
- 3. Keep the iron always** in vertical position when you are not using it.

CNS

- 1. 首次使用前，**请先清理掉所有粘附残留物并用一片湿布轻轻地擦拭。首次开机时，熨斗可能会在短时间内发出异味。
- 2. 将插头插入电源插座。**电源指示灯点亮。通过旋转温度旋钮设置合适的温度。当指示灯熄灭时，即表示熨斗已准备就绪。
- 3. 不使用熨斗时，**请将其竖立放置。

CNT

- 1. 初次使用前，**請先拿抹布沾濕後將產品表面上所殘留的黏著劑擦拭乾淨。第一次使用時，可能有異味排出。此為暫時現象。
- 2. 將電源線插入插座 – 指示燈隨即亮起。**將溫度調控鈕轉到適當的設定值。指示燈熄滅後，熨斗即可使用。
- 3. 不使用時，**請將熨斗豎立放置。

KR

- 1. 처음 사용하기 전에** 모든 접착성 부착물을 제거하고 살짝 젖은 천으로 부드럽게 닦으십시오. 처음 전원을 켤 때 일시적으로 냄새가 날 수 있습니다.
- 2. 전원 케이블 플러그를** 전원 소켓에 연결합니다. 전원 표시등이 켜집니다. 온도 조절기를 돌려 원하는 온도로 설정합니다. 등이 켜지면 다리미를 사용할 준비가 된 것입니다.
- 3. 다리미를 사용하지 않을 때는 항상 세로로 세워두십시오.**

Ironing chart / 织物熨烫设置表 / 熨烫参考表 / 소재별 다리미질 가이드

EN

Fabric	Temperature setting	Ironing recommendation
Acrylic, Acetate, Nylon, Synthetics, Rayon, Viscose	●	Iron on reverse side while still damp or use spray to dampen.
Silk, Cotton blends, Wool & wool blends	●●	Iron on reverse side. Use an ironing cloth to prevent shine marks. Check label and follow manufacturer's instructions. For blends, use setting for the fibre requiring lowest setting.
Cotton, Corduroy, Linen, Denim	●●●	Iron while still damp or use spray to dampen. Use ironing cloth to prevent shine marks, especially with dark colours.

Tips: Always start ironing the fabrics that require low ironing temperature setting, and then increase the temperature setting for fabrics which require higher temperature. The iron heats up faster than it cools down.

CNS

织物	溫度設置	熨燙建議
腈纶、醋酸纤维、尼龙、合成纤维、人造纤维、粘胶纤维	●	当衣物潮湿时或用喷雾润湿时，熨烫织物背面。
丝绸、棉混纺、羊毛及羊毛混纺	●●	熨烫织物背面。使用压熨布熨烫，以防出现闪光熨斑。检查衣物标签并按照制造商说明处理。混纺织物请从织物设置中选择最低设置。
棉质、绒布、亚麻、牛仔布	●●●	当衣物潮湿时或用喷雾润湿时，熨烫织物背面。使用压熨布熨烫，以防出现闪光熨斑，在熨烫深色衣物时更要如此。

小贴士：请务必先熨烫具有较低温度设置要求的织物，然后再逐渐提高温度设置，熨烫具有较高温度设置要求的织物。此熨斗的升温速度要快过冷却速度。

CNT

織物	溫度設定	熨燙操作建議
壓克力織、醋酸纖維、尼龍、合成纖維、人造絲、嫘縈纖維	●	趁衣物尚未全乾時於反面乾熨，或利用灑水功能潤濕。
絲、棉混紡、羊毛及羊毛混紡	●●	於反面熨燙。熨燙時請隔著另一塊布料操作，以免燙出亮光。請依照標籤上的指示操作。混紡織物請將溫度設定調到建議範圍的最低值。
棉、燈芯絨、麻、牛仔布	●●●	趁衣物尚未全乾時於反面乾熨，或利用灑水功能潤濕，於反面熨燙。熨燙時請隔著另一塊布料操作以避免燙出亮光，尤其是暗色衣物。

小贴士：请务必先熨烫具有较低温度设置要求的织物，然后再逐渐提高温度设置，熨烫具有较高温度设置要求的织物。此熨斗的升温速度要快过冷却速度。

KR

소재	온도 설정	다리미질 권장사항
아크릴, 아세테이트, 나일론, 합성섬유, 레이온, 비스코스	●	젖어 있을 때 반대쪽을 다리미질하거나 분무 버튼을 사용해 천을 적시십시오.
실크, 면혼방, 울 및 울혼방	●●	반대쪽을 다리미질하십시오. 다리미질 천을 사용해 번들거리는 흔적이 남지 않게 하십시오. 레이블을 확인하고 제조업체의 지침을 따르십시오. 혼방의 경우, 가장 낮은 설정을 요구하는 소재를 위한 설정을 사용하십시오..
면, 코듀로이, 리넨, 데님	●●●	아직 젖어 있을 때 다리미질하거나 분무 버튼을 사용해 천을 적시십시오. 특히 어두운 색의 소재는 다리미질 천을 사용해 번들거리는 흔적이 남지 않게 하십시오.

팁: 항상 낮은 다리미 온도 설정을 요구하는 소재부터 다리미질한 다음 더 높은 온도를 요구하는 소재를 위한 설정으로 온도를 높여나가십시오. 다리미는 냉각 속도보다 가열 속도가 빠릅니다.

EN

1. Always store iron on its heel rest.
To clean exterior surfaces, use a damp soft cloth and wipe dry. Do not use any chemical solvents, as these will damage the surface.

2. Cleaning the soleplate. Do not use scouring pads or harsh cleaners on the soleplate as these will damage the surface. To remove burnt residue, iron over a damp cloth while iron is still hot. To clean the soleplate, simply wipe with soft damp cloth and wipe dry.

CNS

1. 请务必将熨斗存放在熨斗架上。如要清洁外表面，请使用一片浸湿的软布擦拭并在清洁后擦干。请勿在清洁时使用任何化学溶剂，否则会造成表面损伤。

2. 清洁底板。请勿使用磨砂垫或强效清洁剂清洁底板，否则会造成底板表面损伤。如要清理掉任何烧蚀残留，请将仍然处于高温状态下的熨斗放在一片湿布上熨烫。如要清洁底板，请直接用一片软布擦拭并擦干即可。

CNT

1. 收納時應以直立方式置放。若要清理產品表面，請先拿抹布沾濕後擦拭，再以乾布抹乾。清理時應避免使用化學清潔劑，否則可能會對錶面造成損傷。

2. 清理底板。清理時應避免使用刮布或具強蝕性之清潔劑，否則可能會對表面造成損傷。底板上若有燒焦的殘留物質，只要於加熱後在濕布上來回熨燙即可移除。清理底板時，請先拿抹布沾濕後擦拭，再以乾布抹乾。

KR

1. 항상 다리미를 다리미 거치대쪽으로 세워서 보관하십시오. 외부 표면을 청소할 때에는 살짝 젖은 부드러운 천을 사용해 닦은 다음 물기를 닦아내십시오. 화학 용액은 표면을 손상시킬 수 있으므로 사용하지 마십시오.

2. 다리미 밀판 청소: 수세미나 강한 클리너는 밀판 표면을 손상시킬 수 있으므로 사용하지 마십시오. 그을린 자국을 없애려면 다리미가 뜨거운 동안에 젖은 천 위를 다리미질하십시오. 밀판을 청소하려면 살짝 젖은 천으로 닦은 다음 물기를 닦아내기만 하면 됩니다.

Troubleshooting / 故障排除 / 故障排除 / 문제해결

Problem	Possible cause	Solution
Soleplate is not heating, even though iron is turned on.	Connection problem.	Check main power supply cable, plug and outlet.
	Temperature control is in MIN position.	Select adequate temperature.

EN

问题	可能原因	解决方案
熨斗已经开机，但底板仍未开始加热。	接线故障。	检查电源线、插头和电源插座。
	温度控制开关处于最低 (MIN) 档位。	请选择合适的温度。

CNS

現象	可能原因	解決方法
噴水功能無法運作。開關已開啟，但底板卻沒有加熱的現象。	電源連接有問題。	檢查電源線、插頭和插座。
	溫度。溫度調節鈕處於「小」的檔位。	請按需要設定適當的溫度。

CNT

문제	가능한 원인	해결방법
다리미를 켜도 밀판이 가열되지 않습니다.	연결 문제	주 전원 공급 케이블, 플러그 및 소켓을 확인하십시오.
	온도 조절기가 MIN (최소) 위치에 있습니다.	적절한 온도를 선택하십시오.

KR

Disposal / 报废 / 產品丟棄須知 / 폐기

<p>EN</p>	<p>Packaging materials The packaging materials are environmentally friendly and can be recycled. The plastic components are identified by markings, e.g. >PE<, >PS<, etc. Please dispose the packaging materials in the appropriate container at the community waste disposal facilities.</p>	<p>Old appliance  The symbol  on the product or on its packaging indicates that this product may not be treated as household waste. Instead it shall be handed over to the applicable collection point for the recycling of electrical and electronic equipment. By ensuring this product is disposed</p>	<p>of correctly, you will help prevent potential negative consequences for the environment and human health, which could otherwise be caused by inappropriate waste handling of this product. For more detailed information about recycling of this product, please contact your local city office, your household waste disposal service or the shop where you purchased the product.</p>
<p>CNS</p>	<p>包装材料 本产品包装材料为环保型材料，可以回收处理。这些塑料组件上采用了特殊的标志进行标记，例如“>PE<”、“>PS<”。如要丢弃，请将包装材料放入社区资源回收桶中。</p>	<p>废旧产品  产品或其包装材料的符号  表示本产品不可视为家用垃圾进行处理。而是应该将其交给适当的电气及电子设备回收点进行回收。通过确保本产品能够正确报废处理，您可以避免因本产品处理</p>	<p>不当而引起的对环境及人类健康造成的潜在负面影响。如需了解有关本产品回收的更多详情，请联系您在城市的办事处、您的家用废物处理咨询点或您采购本产品的零售点。</p>
<p>CNT</p>	<p>包裝材料 本產品所使用的包裝材料均可回收。其中屬於塑膠材質的部分均有「PE」、「PS」等標示，故請依照當地的廢棄物回收分類製度丟棄之。</p>	<p>舊家電  本產品和包裝上有清楚標示 ，不得當作家庭垃圾丟棄。丟棄時應送往適當的電器用品回收地點。只要以正確的方式處置本產品，您就可以為環保盡一份</p>	<p>心力，避免未來對環境或人類的健康造成威脅。若要瞭解更多有關於產品回收的資訊，請向當地政府機關、廢棄物回收業者或零售店家詢問。</p>
<p>KR</p>	<p>포장재 포장재는 환경친화적인 소재로 제작되었으며 재활용 가능합니다. 플라스틱 구성요소에는 >PE<, >PS< 등의 표시가 되어 있습니다. 포장재는 현지 폐기물 처리 시설이 정한 적절한 방법과 절차에 따라 폐기하십시오.</p>	<p>오래된 가전제품  제품이나 포장에 명시된  기호는 해당 제품이 가정 폐기물로 취급되어서는 안 된다는 내용을 의미합니다. 가정 폐기물로 배출하는 대신 전기 및 전자 기기의 재활용을 위해 해당 수집 기관에 전달해야 합니다. 본 제품을 올바르게</p>	<p>폐기함으로써, 본 제품의 부적절한 폐기로 인해 발생할 수 있는 환경 및 인간의 건강에 대한 부정적인 결과를 방지하도록 도울 수 있습니다. 본 제품의 재활용에 관한 자세한 내용은 현지의 관련 기관이나 가정 폐기물 처리 전달 기관 또는 제품을 구입한 매장에 문의하십시오.</p>

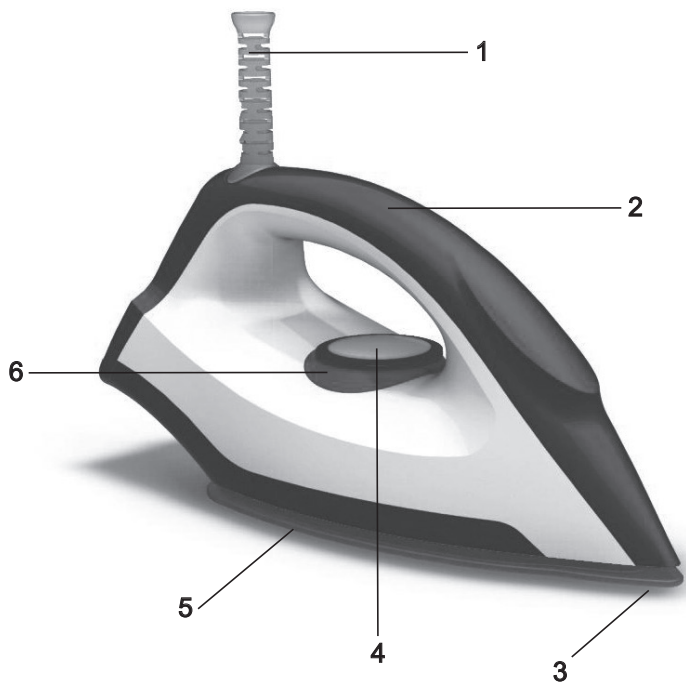

ID

Komponen

1. Pelindung kabel listrik
2. Gagang
3. Pelindung kancing
4. Pengatur suhu
5. Pelat*
6. Lampu indikator arus listrik

TH

ส่วนประกอบ

1. ปลอกปกป้องสายไฟ
2. มือจับ
3. ร่องปกป้องกระดุม
4. แป้นเลือกอุณหภูมิ
5. หน้าเตารีด*
6. ไฟแสดงสถานะ

VN

Các bộ phận

1. Lớp bảo vệ dây điện
2. Tay cầm
3. Tấm bảo vệ nút
4. Núm chọn nhiệt độ
5. Tấm đế*
6. Đèn báo nguồn điện

*spesifikasi tergantung dari model masing-masing / ข้อกำหนดเฉพาะจะแตกต่างกันในแต่ละรุ่น / Thông số kĩ thuật thay đổi tùy theo mẫu

Petunjuk Keselamatan / คำแนะนำด้านความปลอดภัย / Lỗi khuyên an toàn

<p>ID</p>	<p>Silahkan membaca petunjuk berikut sebelum menggunakan setrika ini pertama sekali.</p> <ul style="list-style-type: none"> • Setrika ini tidak boleh digunakan oleh mereka (termasuk anak-anak) yang menderita cacat fisik, indra atau mental serta mereka yang tidak memiliki pengalaman atau pengetahuan kecuali pengguna tersebut telah mendapatkan petunjuk keselamatan dari orang yang bertanggung-jawab. • Anak-anak harus diawasi dalam menggunakan setrika ini agar tidak menggunakan dengan sembarangan. • Setrika ini harus tersambung pada sumber listrik yang memiliki tegangan dan frekuensi sesuai dengan spesifikasi pelat dasar. 	<ul style="list-style-type: none"> • Jangan gunakan setrika apabila setrika pernah terjatuh atau apabila terdapat tanda-tanda kerusakan pada setrika atau kabel ataupun bila ada kebocoran. • Setrika ini harus dipasang pada soket yang telah dibumikan. • Jika setrika atau kabel listrik rusak, komponen yang rusak tersebut harus diganti oleh pabrik, agen service atau seseorang yang telah terlatih untuk menghindarkan bahaya. • Setrika harus digunakan dan diletakkan pada permukaan kokoh. Bila setrika terletak pada dudukan, pastikan dudukan berada pada permukaan yang kokoh 	<ul style="list-style-type: none"> • Jangan biarkan menyala tanpa digunakan. • Matikan setrika dan cabut kabel setelah selesai menggunakan dan sebelum melakukan pembersihan atau perawatan. • Jangan biarkan kabel tersentuh oleh bagian setrika yang panas. • Setrika tidak boleh terendam air atau cairan lain. • Setrika ini hanya boleh digunakan di rumah. Pabrik tidak bertanggung-jawab apabila terjadi kerusakan yang diakibatkan oleh penggunaan yang salah.
<p>TH</p>	<p>อ่านคำแนะนำต่อไปนี้ให้เข้าใจก่อนใช้เตารีดเป็นครั้งแรก</p> <ul style="list-style-type: none"> • ห้ามบุคคล (รวมถึงเด็กเล็ก) ที่ศึกษาทางกายไม่สมบูรณ์ มีความบกพร่องทางระบบการรับรู้หรือภาวะทางจิตใจ หรือขาดประสบการณ์และความรู้ใช้เตารีด เว้นแต่ได้รับการดูแลหรือคำแนะนำเกี่ยวกับวิธีการใช้โดยบุคคลที่รับผิดชอบเรื่องความปลอดภัยของบุคคลเหล่านั้น • เด็กควรอยู่ในความควบคุมเสมอเพื่อป้องกันไม่ให้เด็กเล่นกับเตารีด • ต้องเสียบปลั๊กเตารีดเข้ากับแหล่งจ่ายไฟที่มีแรงดันไฟฟ้าและความถี่ตรงกับข้อกำหนดเฉพาะที่อยู่บนแผ่นระบุข้อมูลนี้ 	<ul style="list-style-type: none"> • ห้ามใช้เตารีดหากเปลือยหรือเตารีดที่มีร่องรอยความชำรุดเสียหายที่มองเห็นได้ หรือความเสียหายบริเวณสายไฟหรือมีน้ำรั่วออกมา • ต้องเสียบปลั๊กของเตารีดเข้ากับเต้าเสียบที่ต่อสายดินเท่านั้น • หากเตารีดหรือสายไฟชำรุดเสียหาย ต้องให้ผู้ผลิต ศูนย์บริการหรือช่างผู้ชำนาญเป็นผู้เปลี่ยนเท่านั้นเพื่อหลีกเลี่ยงอันตรายที่อาจเกิดขึ้น • ต้องใช้และวางเตารีดบนพื้นผิวที่มั่นคง เมื่อวางเตารีดบนแท่นวางของเตารีด พื้นผิวที่วางแท่นวางต้องมั่นคง 	<ul style="list-style-type: none"> • ห้ามวางเตารีดที่เสียบปลั๊กแล้วทิ้งไว้โดยไม่มีคนดูแล • ต้องปิดสวิตช์เตารีดและดึงปลั๊กออกทุกครั้งหลังจากใช้งานแล้ว ก่อนทำความสะอาดและบำรุงรักษา • สายไฟหลักของเตารีดต้องไม่สัมผัสกับส่วนที่ร้อนของเตารีด • ห้ามจุ่มเตารีดในน้ำหรือของเหลวอื่นๆ • เตารีดผลิตขึ้นเพื่อใช้ภายในบ้านเท่านั้น ผู้ผลิตไม่สามารถรับผิดชอบต่อความเสียหายที่อาจเกิดขึ้นจากการใช้อย่างไม่เหมาะสมหรือไม่ถูกต้อง
<p>VN</p>	<p>Đọc kỹ hướng dẫn sau đây trước khi sử dụng bàn ủi lần đầu tiên.</p> <ul style="list-style-type: none"> • Thiết bị này được sản xuất không dành cho những người sử dụng (kể cả trẻ em) bị suy giảm thể chất, giác quan hoặc tâm thần, hoặc thiếu kinh nghiệm và kiến thức, trừ khi họ được giám sát hoặc hướng dẫn sử dụng thiết bị bởi người có trách nhiệm đảm bảo an toàn cho họ. • Trẻ em phải được giám sát để đảm bảo rằng chúng không chơi với thiết bị này. • Chỉ cắm điện khi điện áp và tần số phù hợp với các thông số kỹ thuật trên bảng điện định mức. 	<ul style="list-style-type: none"> • Không sử dụng bàn ủi nếu bàn ủi bị rơi, bị hư hỏng trên thân bàn ủi hoặc trên dây cắm hoặc bị rò rỉ. • Chỉ nên cắm bàn ủi vào một ổ cắm điện đã được nối đất. • Nếu thiết bị hoặc dây cắm bị hỏng, nó cần được thay thế bởi nhà sản xuất, đại lý dịch vụ của nhà sản xuất hoặc người có khả năng sửa chữa tương tự để tránh nguy hiểm. • Bàn ủi cần được sử dụng và được đặt trên một bề mặt chắc chắn. Khi dụng bàn ủi trên chân đế, đảm bảo chân đế được đặt trên bề mặt chắc chắn. 	<ul style="list-style-type: none"> • Không bao giờ được bỏ đi nơi khác khi bàn ủi đang cắm điện. • Tắt thiết bị và rút phích cắm chính sau mỗi lần sử dụng, trước khi làm sạch và bảo trì. • Không để dây điện tiếp xúc với bất kỳ bộ phận nóng nào của bàn ủi. • Không nhúng bàn ủi vào nước hoặc bất cứ chất lỏng nào khác. • Thiết bị này được thiết kế chỉ để sử dụng trong nhà. Nhà sản xuất không chịu trách nhiệm cho những thiệt hại có thể gây ra từ việc sử dụng không đúng hoặc không phù hợp.

Memulai penggunaan / เริ่มต้นใช้งาน / Bắt đầu

1. Sebelum menggunakan untuk pertama sekali. Cabut semua lakban yang ada dan bersihkan setrika dengan kain basah. Saat menyalakan untuk pertama sekali, anda mungkin akan mencium bau tidak sedap.

1. ก่อนใช้งานอุปกรณ์ครั้งแรก ทำความสะอาดกาวทั้งหมดที่เหลืออยู่บนอุปกรณ์และเช็ดเบาๆ ด้วยผ้าชุบน้ำหมาดๆ เมื่อเปิดอุปกรณ์เป็นครั้งแรก อาจเกิดกลิ่นเหม็นขึ้นชั่วคราว

1. Trước khi sử dụng lần đầu tiên. Hãy loại bỏ tất cả các phần cặn bã dính kết và chà nhẹ bằng giẻ ướt. Khi lần đầu tiên bật, sẽ tạm thời có mùi.

2. Cắm dây cáp điện vào ổ cắm điện. Đèn báo nguồn điện bật sáng.

2. Pasang kabel pada soket listrik. Lampu indikator akan menyala. Pilih pengaturan suhu yang tepat. Bila lampu indikator mati, setrika telah siap untuk digunakan.

2. เสียบปลั๊กเข้ากับเต้าเสียบ ไฟแสดงสถานะจะสว่างขึ้น ตั้งอุณหภูมิเตารีดโดยหมุนเป็นเลือกอุณหภูมิไปยังระดับอุณหภูมิที่ต้องการ เมื่อไฟดับลง แสดงว่าเตารีดพร้อมใช้งานแล้ว

Thiết lập nhiệt độ bằng cách xoay núm chọn nhiệt độ sang lựa chọn phù hợp. Khi đèn tắt, bàn là đã sẵn sàng sử dụng.

3. Luôn để bàn là ở vị trí thẳng đứng khi quý vị không sử dụng.

3. Selalu letakkan setrika pada posisi berdiri saat setrika sedang tidak digunakan.

3. วางเตารีดในแนวตั้งเสมอเมื่อไม่ได้ใช้งาน

ID

TH

VN

Tabel setrikaan / ตารางรีดผ้า / Bảng là ủi

ID

Kain	Pengaturan suhu	Saran menyetrika
Akriilik, Asetat, Nilon, Sintetis, Rayon, Viscose	●	Setrika pada sisi sebaliknya saat masih basah atau gunakan semprotan untuk membasahi.
Sutra, Campuran katun, Wool & campuran wool	●●	Setrika pada sisi sebaliknya. Gunakan kain setrikaan agar tidak ada garis pada kain. Baca dan ikuti petunjuk pabrik. Untuk bahan campuran, gunakan pengaturan untuk serat dengan pengaturan terendah.
Katun, Corduroy, Linen, Denim	●●●	Setrika saat masih basah atau gunakan semprotan untuk membasahi. Gunakan kain setrikaan agar tidak ada garis pada kain, khususnya pada kain berwarna gelap.

Kiat penting: Selalu mulai menyetrika kain dengan pengaturan suhu yang rendah dan kemudian ubah suhu menjadi lebih tinggi untuk kain yang memerlukan suhu yang lebih panas. Suhu setrika lebih cepat meningkat daripada menurun.

TH

ชนิดของผ้า	การตั้งอุณหภูมิ	คำแนะนำในการรีดผ้า
อะคริลิก, อะซิเตท, ไนลอน, ผ้าใยสังเคราะห์, เรยอน, วิสโคส	●	รีดด้านหลังของผ้าขณะที่ผ้ายังชื้นอยู่หรือฉีดละอองน้ำลงบนผ้าก่อนรีด
ผ้าไหม, ผ้าฝ้ายผสม, ขนสัตว์, ผ้าขนสัตว์ผสม	●●	รีดด้านหลังของผ้า ใช้ผ้ารองรีดเพื่อป้องกันการเกิดรอยแหว่ราวบนผ้า ตรวจสอบป้ายเสื้อผ้าและปฏิบัติตามคำแนะนำของผู้อผลิต สำหรับผ้าเส้นใยผสม ควรตั้งอุณหภูมิให้เหมาะสมกับเส้นใยผ้าที่ต้องการอุณหภูมิต่ำที่สุด
ผ้าฝ้าย, ผ้าริ้ว, ผ้าลินิน, ผ้ายีนส์	●●●	รีดผ้าขณะที่ผ้ายังชื้นอยู่หรือฉีดน้ำลงบนผ้าก่อนรีด ใช้ผ้ารองรีดเพื่อป้องกันการเกิดรอยแหว่ราวบนผ้า โดยเฉพาะอย่างยิ่งผ้าที่มีสีเข้ม

เคล็ดลับ: เริ่มต้นรีดผ้าโดยรีดเสื้อผ้าที่ต้องรีดด้วยอุณหภูมิต่ำก่อนเสมอ จากนั้นจึงเพิ่มอุณหภูมิเมื่อต้องรีดผ้าที่ต้องรีดด้วยอุณหภูมิสูงขึ้น เตารีดจะทำความร้อนได้เร็วกว่าการเย็นตัวลง

VN

Vải	Thiết lập nhiệt độ	Khuyến nghị là ủi
Acrylic, Acetate, Ni-lông, Sợi Tổng Hợp, Tơ Nhân Tạo, Sợi Viscô	●	Là mặt trái khi vẫn đang ẩm hoặc sử dụng chế độ phun để làm ẩm.
Lụa, vải Cotton pha trộn, Len & len pha trộn	●●	Là mặt trái. Sử dụng tấm vải là quần áo để tránh các vết cháy. Kiểm tra nhãn và làm theo các hướng dẫn của nhà sản xuất. Đối với vải pha, sử dụng chế độ thiết lập cho vải mà yêu cầu chế độ thiết lập thấp nhất.
Vải Cotton, Nhung kẻ, Vải lanh, Vải bông chéo	●●●	Là trong khi vẫn đang ẩm hoặc sử dụng nút phun để làm ẩm. Sử dụng tấm vải là quần áo để tránh các vết cháy, đặc biệt là đối với quần áo tối màu.

Lời khuyên: Luôn bắt đầu là quần áo yêu cầu thiết lập nhiệt độ là thấp và sau đó tăng nhiệt độ cho các quần áo yêu cầu nhiệt độ cao hơn. Bàn là nóng nhanh hơn so với khi nguội đi.

1. Selalu simpan setrika pada dudukannya. Untuk membersihkan bagian luar, gunakan kain basah dan lap sampai kering. Jangan gunakan larutan kimia sebab hal ini dapat mengakibatkan kerusakan pada permukaan.

1. เก็บเตารีดโดยวางบนฐานรองเสมอ หากต้องการทำความสะอาดผิวด้านนอก ให้เช็ดด้วยผ้าชุบน้ำหมาดๆ หรือผ้าแห้ง ห้ามใช้สารเคมี เนื่องจากอาจทำให้พื้นผิวของเตารีดเสียหายได้

1. Luôn cất bàn là trên giá đỡ có chân đố. Để vệ sinh bề mặt bên ngoài, hãy sử dụng miếng giẻ mềm ướt và lau khô. Không được sử dụng bất kỳ dung môi hóa học nào, vì điều này sẽ làm tổn hại đến bề mặt.

2. Bersihkan bagian pelat. Jangan gunakan sabut atau sikat yang keras sebab hal ini dapat mengakibatkan kerusakan pada permukaan. Untuk membersihkan residu yang terbakar, usapkan setrika pada kain basah saat setrika masih panas. Untuk membersihkan pelat, cukup lap dengan kain basah dan lap hingga kering.

2. การทำความสะอาดหน้าเตารีด ห้ามใช้แผ่นขัดหรือสารทำความสะอาดที่มีฤทธิ์รุนแรงบนหน้าเตารีดเนื่องจากอาจทำให้พื้นผิวได้รับความเสียหาย หากต้องการขจัดรอยไหม้บนหน้าเตารีด ให้รีดผ้าเปียกนำขณะที่เตารีดกำลังร้อน หากต้องการทำความสะอาดหน้าเตารีด ควรเช็ดด้วยผ้าชุบน้ำหมาดๆ หรือผ้าแห้ง

2. Vệ sinh tấm đế. Không được sử dụng miếng cọ rửa hoặc chất tẩy rửa mạnh lên tấm đế vì điều này sẽ làm tổn hại đến bề mặt. Để loại bỏ chất cặn bã bị cháy, lau bàn là bằng miếng giẻ ướt khi bàn là còn nóng. Để vệ sinh tấm đế, chỉ cần lau bằng miếng giẻ mềm ướt và lau khô.

ID

TH

VN

Pemecahan masalah / การแก้ไขปัญหา / Khắc phục sự cố

ID	Permasalahan	Kemungkinan Penyebab	Solusi
	Pelat tidak panas walaupun setrika sudah menyala.	Masalah pada sambungan listrik	Periksa sambungan kabel listrik dan pasang pada soket dinding.
		Pengatur suhu berada pada posisi MIN.	Pilih pengaturan yang sesuai.

TH	ปัญหา	สาเหตุที่อาจเป็นไปได้	วิธีแก้ไข
	หน้าเตารีดไม่ร้อน ถึงแม้ว่าจะเปิดเตารีดแล้ว	ปัญหาการเชื่อมต่อ	ตรวจสอบสายจ่ายไฟหลัก ปลั๊ก และเต้าเสียบ
		เป็นเลือกอุณหภูมิอยู่ในตำแหน่ง MIN (อุณหภูมิต่ำสุด)	เลือกอุณหภูมิที่เหมาะสม

VN	Vấn đề	Nguyên nhân có thể có	Giải pháp
	Tấm đế không nóng, mặc dù đã bật bàn là.	Vấn đề về kết nối.	Kiểm tra cáp nguồn điện chính, phích cắm và ổ cắm.
		Điều chỉnh nhiệt độ ở vị trí MIN.	Chọn nhiệt độ phù hợp

Bahan pembungkus

Bahan pembungkus adalah bahan yang ramah lingkungan dan dapat didaur-ulang. Bahan-bahan dari plastik dapat diketahui dari tanda-tanda yang tertera seperti >PE<, >PS<, dll. Harap buang bahan-bahan pembungkus pada tempat pembuangan sampah yang sesuai.

Setrika lama



Simbol khusus pada produk atau bungkusnya menandakan bahwa produk ini tidak dapat diproses sebagai limbah rumah tangga. Sebaliknya produk tersebut harus dibawa ke tempat penampungan alat-alat listrik yang akan didaur-ulang. Dengan membuang setrika in pada tempat yang benar, anda telah turut melindungi lingkungan serta keselamatan manusia yang dapat

terkena dampak buruk penanganan yang salah akan limbah produk ini. Untuk keterangan lebih lanjut mengenai proses daur ulang produk ini, silahkan menghubungi dinas kebersihan kota anda, layanan pembuangan limbah atau toko tempat anda membeli produk ini.

Model No.: EDI1004, EDI1014
 Importer/Importir: PT. Electrolux Indonesia, Jakarta
 No. DEPDA: I.38.EI.3.01001.1016

ID

วัสดุที่ใช้สำหรับบรรจุภัณฑ์

วัสดุที่ใช้สำหรับบรรจุภัณฑ์เป็นมิตรกับสิ่งแวดล้อมและสามารถนำมารีไซเคิล ส่วนประกอบที่เป็นพลาสติกเห็นได้จากเครื่องหมายต่างๆ เช่น >PE<, >PS< เป็นต้น โปรดทิ้งวัสดุที่ใช้สำหรับบรรจุภัณฑ์ลงในภาชนะที่เหมาะสมที่ทางการจัดเตรียมไว้ให้

เตารีดเครื่องเก่า



สัญลักษณ์ที่อยู่บนผลิตภัณฑ์หรือบนบรรจุภัณฑ์แสดงให้ทราบว่า ห้ามทิ้งผลิตภัณฑ์เหล่านี้เสมือนหนึ่งของเสียภายในครัวเรือน แต่ควรส่งไปที่จุดรวบรวมที่เหมาะสมเพื่อการรีไซเคิลอุปกรณ์ไฟฟ้าและอุปกรณ์อิเล็กทรอนิกส์ การกำจัดผลิตภัณฑ์อย่างเหมาะสมจะช่วยป้องกันผลร้ายที่อาจเกิดขึ้น

กับสิ่งแวดล้อมและสุขภาพอนามัย ที่อาจมีสาเหตุมาจากการจัดการกับผลิตภัณฑ์นี้ อย่างไม่ถูกต้อง หากต้องการข้อมูลเพิ่มเติมเกี่ยวกับวิธีการรีไซเคิลผลิตภัณฑ์นี้ โปรดติดต่อเจ้าหน้าที่ที่เกี่ยวข้องในพื้นที่ฝ่ายบริการกำจัดขยะในครัวเรือน หรือร้านที่คุณซื้อผลิตภัณฑ์

TH

Vật liệu bao bì

Các vật liệu bao bì thân thiện môi trường và có thể được tái chế. Các thành phần nhựa được xác định bởi các dấu hiệu, ví dụ như > PE <, > PS <, v.v... Vui lòng bỏ các vật liệu bao bì trong các thùng chứa thích hợp tại các cơ sở xử lý chất thải của cộng đồng.

Đồ gia dụng cũ



Các biểu tượng trên sản phẩm hoặc trên bao bì của nó chỉ ra rằng sản phẩm này có thể không được xử lý như rác sinh hoạt. Thay vào đó, nó nên được bàn giao cho các điểm thu gom thích hợp cho việc tái chế các thiết bị điện và điện tử. Bằng cách đảm bảo sản phẩm này được xử lý một cách chính xác, bạn sẽ giúp ngăn ngừa

những hậu quả tiêu cực đối với môi trường và sức khỏe con người có thể xảy ra do xử lý chất thải không phù hợp. Để biết thông tin chi tiết hơn về việc tái chế sản phẩm này, vui lòng liên hệ với chính quyền thành phố bạn sinh sống, dịch vụ xử lý rác thải sinh hoạt hoặc cửa hàng nơi bạn đã mua sản phẩm.

VN

中国

伊莱克斯（中国）电器有限公司 上海小家电分公司
中国，上海，静安区共和新路1968号大宁国际广场
8号楼606室
办公电话: +86 21 3178 1000
传真: +86 21 3387 0368
售后服务: +86 9510 5801
网站: www.electrolux.com.cn

台湾

新加坡商伊莱克斯股份有限公司 台湾分公司
22065新北市板橋區縣民大道2段68號9F
免付費客服專線: 0800-888-259
傳真: 886-2-8964-5269
電郵: service@electrolux.com.tw
網站: www.electrolux.com.tw

KOREA

Electrolux Korea limited
9F, Pine Avenue B,
100 Euljiro, Jung-gu, Seoul, Korea 04551
Korea
Tel : +82 2 6020-2200
Fax: +82 2 6020-2271-3
Customer Care Services : +82 1566-1238
Email : homecare.krh@electrolux.com
Website: www.electrolux.co.kr

INDONESIA

PT Electrolux Indonesia
Jl. Abdul Muis No.34, Petojo Selatan, Gambir,
Jakarta Pusat 10160, Indonesia
Hotline Service: 0804 111 9999
SMS: 0812 8088 8863
WA: 0811 8339 777
Email: customercare@electrolux.co.id Website:
www.electrolux.co.id
Diimpор oleh PT Electrolux Indonesia.

PHILIPPINES

Electrolux Philippines, Inc.
10th Floor, W5th Avenue Building
5th Avenue Corner 32nd Street
Bonifacio Global City,
Taguig Philippines 1634
Trunkline: +63 2 737 4756
Domestic Toll Free: 1 800 10 845 care 2273
Customer Care Services: +63 2 845 care 2273
Email: wecare@electrolux.com
Website: www.electrolux.com.ph

THAILAND

Electrolux Thailand Co Ltd
Electrolux Building
14th Floor 1910 New Petchburi Road Bangkokpi,
Huay Kwang
Bangkok 10310
Thailand
Tel: +66 2 725 9100
Fax: +66 2 725 9299
Customer Care Services: +66 2 725 9000 Email:
customercarethai@electrolux.com Website:
www.electrolux.co.th

VIETNAM

Electrolux Vietnam Ltd
Floor 9th, A&B Tower
76 Le Lai Street
Ben Thanh Ward - District 1
Ho Chi Minh City
Vietnam
Tel: +84 8 3910 5465
Fax: +84 8 3910 5470
Customer Care Services: 1800-58-8899
Email: vncare@electrolux.com
Website: www.electrolux.vn

MALAYSIA

Electrolux Home Appliances Sdn Bhd
Lot C6, No. 28, Jalan 15/22,
Taman Perindustrian Tiong Nam,
40200 Shah Alam, Selangor
Malaysia
Customer Care Services Tel: +60 3 5525 0800
Customer Care Services Fax: +60 3 5524 2521
Email: malaysia.customercare@electrolux.com
Website: www.electrolux.com.my

SINGAPORE

Electrolux SEA Pte Ltd
1 Fusionopolis Place, Galaxis
#07-10 (West Lobby)
Singapore 138522
Customer Care Services: +65 6727 3699
Fax: +65 6727 3611
Email: customer-care.sin@electrolux.com
Website: www.electrolux.com.sg

AUSTRALIA

Electrolux Home Products Pty Ltd
ABN 51 004 762 341
163 O'Riordan Street, Mascot, NSW 2020, Australia
Customer Service Phone: 1300 365 305
Website: www.electrolux.com

NEW ZEALAND

Electrolux Small Appliances
A division of Electrolux (NZ) Limited
3-5 Niall Burgess Road, Mt. Wellington, Auckland,
New Zealand
Phone: (09) 9573 2220
Customer Service Phone: 0508 730 730
Website: www.electrolux.com



Electrolux

Share more of our thinking at
www.electrolux.com